

MODULE 3

Syllabus: **DC Machines:**

DC Generator: Principle of operation, constructional details, induced EMF expression, types of generators. Relation between induced emf and terminal voltage. Simple numerical.

DC Motor: Principle of operation, back emf and its significance. Torque equation, types of motors, characteristics and speed control (armature & field) of DC motors (series & shunt only). Applications of DC motors. Simple numerical.

Introduction:

- An electrical machine, deals with energy transfer either from mechanical to electrical or electrical to mechanical is called **DC Machine**.
- The DC machines are classified into
- i) **DC Generator**
- ii) **DC Motor**
- **DC Generator:** The machine which converts mechanical energy into Electrical energy
- **DC motor:** The machine which converts Electrical energy into Mechanical energy

Working principle of D.C.Machine as a generator

Working principle of D.C.Machine as a generator:

- It is based on the principle of **dynamically induced e.m.f .**
- Whenever a conductor cuts magnetic flux, dynamically induced e.m.f. is produced in the conductor according to the Faradays laws of Electromagnetic Induction. This e.m.f. causes a current to flow in the circuit, if the conductor circuit is closed.
- The emf is given by

$$e = B \cdot l \cdot v \cdot \sin \theta \text{ volts/coil side where,}$$

Where B=the flux density in Tesla,

l=the active length of the coil side in meters

v=the velocity with which the coil is moved in meters/sec and

θ is the angle between the direction of the flux and relative velocity.

- The direction of the induced voltage can be obtained by applying **Fleming's right hand rule**.

Faraday's Law of Electromagnetic Induction

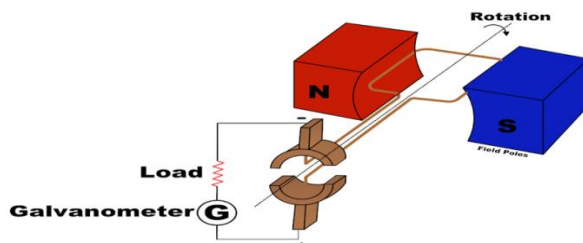

Construction of DC Machine

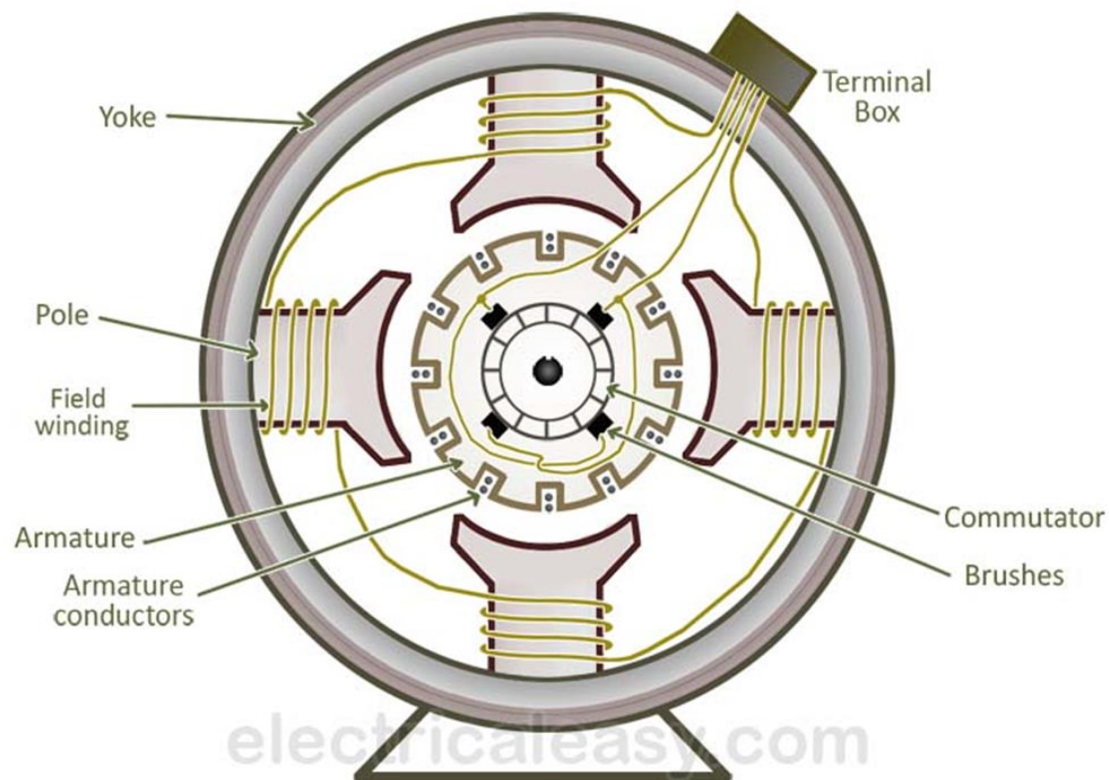

Salient parts of a D.C. Machine are:

- (i) Yoke
- ii) Field system (poles)
- (iii) Armature
- (iv) Commutator
- (v) Brushes

Yoke:

It is made of **cast iron or silicon steel**

- It serves the purpose of **outermost cover** of the D.C. machine. So that the insulating materials get protected from harmful atmospheric elements like moisture, dust and various gases like SO₂, acidic fumes etc.
- It provides mechanical support to the poles,

Poles:

It is made cast iron or cast steel laminations which are stamped together.

Each pole is divided into two parts a) **pole core** and b) **pole shoe**

- Pole core basically carries a field winding which is necessary to produce the flux.
- Pole shoe enlarges the area of armature core to come across the flux, which is necessary to produce larger induced emf. To achieve this, pole shoe has given a particular shape

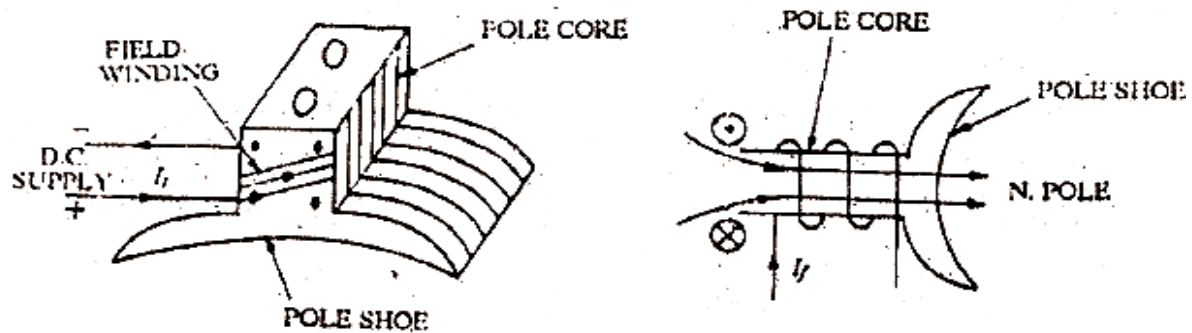

Field winding [F1-F2]:

It is made of conducting material like copper or Aluminum. The field winding is wound on the pole core with a definite direction.

- It carries current due to which the pole core behaves as an electromagnet and produces necessary flux. As it's exciting the pole as electromagnet hence it is also called Exciting winding.

Armature:

- It is further divided into two parts namely,
 - Armature core and
 - Armature winding
- Armature core is cylindrical in shape made up of iron and mounted on the shaft. It is provided with slots on its outer periphery to place the conductor and the air ducts to permit the air flow through armature which serves cooling purpose.
- In order to collect the Emf generated in each conductor they are connected in certain pattern called armature winding.

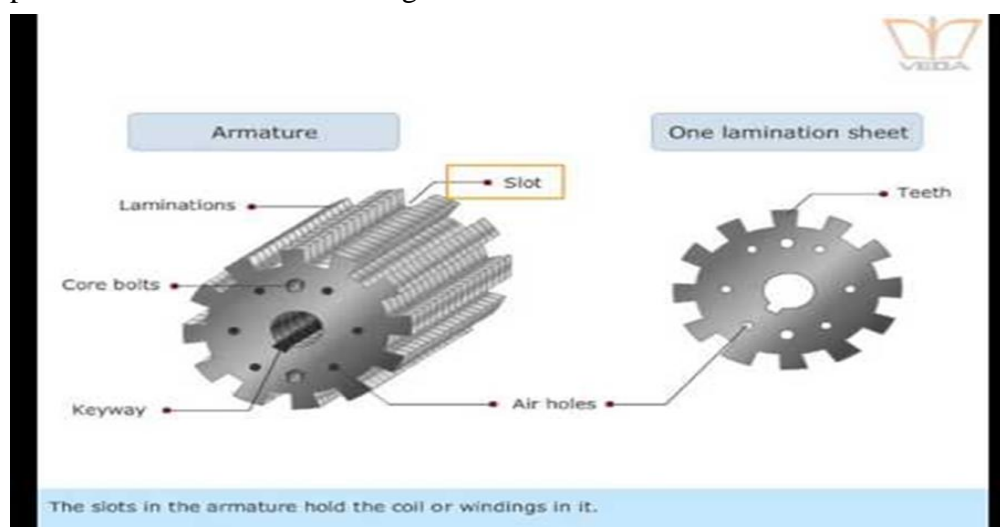

Commutator:

- The basic nature of Emf induced in the armature conductors is alternating. This needs rectifications in case of D.C. generator which is possible by device called commutator.

Brushes and brush gear:

- Brushes collect current from commutator and make it available to the stationary external circuit.
- Ball bearings are usually used as they are more reliable.
- For heavy duty machines, roller bearings are preferred.

Emf Equation of DC Generator:

Let,

Φ = Flux produced by each pole in weber (Wb) and

P = number of poles in the DC generator.

N = speed of the armature conductor in rpm.

Consider a one revolution of the conductor

Total flux produced by all the poles = $\Phi \times P$

Time taken to complete one revolution = $\frac{60}{N}$

Now, according to Faraday's law of induction, the induced EMF of the conductor is equal to rate of change of flux.

$$e = \frac{d\phi}{dt} \text{ and } e = \frac{\text{total flux}}{\text{time take}}$$

Therefore,

Induced EMF of one conductor is

$$e = \frac{\phi P}{\frac{60}{N}} = \phi P \frac{N}{60}$$

Let us suppose there are **Z** total numbers of conductor in a generator, and arranged in such a manner that all parallel paths are always in series.

Here, Z = total numbers of conductor A = number of parallel paths

Then, **Z/A = number of conductors connected in series**

Therefore,

Induced EMF of DC generator

E_g = EMF of one conductor \times number of conductor connected in series.

Induced Emf of DC generator is

$$e = \phi P \frac{N}{60} \times \frac{Z}{A} \text{ volts}$$

$$\mathbf{e = \frac{\phi P N Z}{60 A}}$$

Problems on Emf equation

Formula

$$E_g = \frac{\phi Z N}{60} \times \frac{P}{A} \text{ volt}$$

Φ - flux produced by each pole in wb

Z- total no of conductors in armature

N- speed armature in rpm

P- No of poles

A- No of parallel paths , for wave winding A=2
for lap winding A=P

1. A 4 pole, 1500 rpm DC generator has a lap wound armature having 24 slots with 10 conductors per slot. If the flux per pole is 0.04 Wb, calculate EMF generated in the armature. What would be the generated EMF if the winding is wave connected?

Solution:

Given: P = 4, N = 1500rpm, Lap i. e. A = P = 4, ϕ = 0.04 Wb

Z = Slots X Conductors per Slot = 24 X 10 = 240

$$E_g = \frac{\phi P N Z}{60 A} = \frac{0.04 \times 4 \times 1500 \times 240}{60 \times 4} = 240 \text{ V}$$

If winding is wave connected, A = 2

$$E_g = \frac{0.04 \times 4 \times 1500 \times 240}{60 \times 2} = 480 \text{ V}$$

2. A 4 pole generator with wave wound armature has 51 slots each having 24 conductors. The flux per pole is 0.01 weber. At what speed must the armature rotate to give an induced EMF of 220 V? What will be the voltage developed if the winding is lap connected and the armature rotates at the same speed?

Solution:

Given: $P = 4$, wave connected hence $A = 2$, 51 slots, 24 conductors per slot, $\phi = 0.01 \text{ Wb}$, $E_g = 220 \text{ V}$

$$E_g = \frac{\phi PNZ}{60A} \quad \text{Where } Z = 51 \times 24 = 1224$$

$$220 = \frac{0.01 \times 4 \times N \times 1224}{60 \times 2}$$

$$N = \frac{220 \times 60 \times 2}{0.01 \times 4 \times 1224}$$

i.e $N = 539.2156 \text{ r.p.m}$... speed for 220V

For lap wound, $A = P = 4$ and $N = 539.2156 \text{ r.p.m}$

$$E_g = \frac{\phi PNZ}{60A} = \frac{0.01 \times 4 \times 539.2156 \times 1224}{60 \times 4} = 110 \text{ V}$$

3. A 8 pole DC generator has 500 armature conductors and useful flux per pole of 0.065 wb. What will be EMF generated if the winding is lap connected and runs at 1000 rpm? What must be the speed at which it is to be driven to produce the same EMF if the winding is Wave connected?

Solution:

Given: $P = 8$ $Z = 500$ conductors $\phi = 0.065 \text{ Wb}$, $N = 1000 \text{ rpm}$

When it is lap connected $A = P = 8$ and $E_g = ?$

$$E_g = \frac{\phi PNZ}{60A} = \frac{0.065 \times 8 \times 1000 \times 500}{60 \times 8} = 541.667 \text{ V}$$

ii) $N = ?$ When $E_g = 541.667 \text{ V}$ and winding is wave connected i.e $A = 2$

$$541.667 = \frac{0.065 \times 8 \times N \times 500}{60 \times 2}$$

$$N = \frac{541.667 \times 60 \times 2}{0.065 \times 8 \times 500}$$

$$N = 250 \text{ rpm}$$

Types of DC Generators

- The field winding is also called as exciting winding. Supplying current to the field winding is excitation.
- Depending upon the method of excitation used in the generators are classified into
 - i) Separately excited DC generator
 - ii) Self-excited DC generator.

Separately Excited Generators:

In separately excited dc machines, the field winding is supplied from a **separate power source** as shown in below fig.

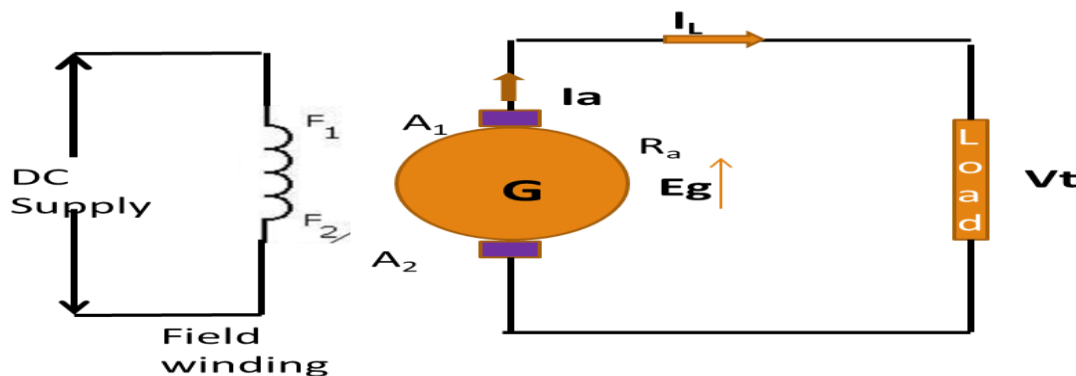

Eg- generated Emf in generator

Ia – Armature current

R_a - armature resistance

I_L - Load current

Vt- Terminal voltage

F1 and F2 – Terminals of field winding

Self-Excited Field Generators:

- The self-excited DC generator produces a magnetic field by itself without DC sources from an external. The electromotive force that produced by generator at armature

winding is supply to a field winding instead of DC source from outside of the generator. Therefore, field winding is necessary connected to the armature winding.

- When generator started, due to residual flux, it develops a small amount of EMF which drives a small current in the field winding. This tends to increase the flux in the poles in turn increases the EMF. This cumulative process continues until generator produces a rated voltage.

They further classified into:

- DC Shunt generator
- DC Series generator
- DC Compound generator.

a) Shunt generator:

- In shunt generator, the field winding is connected in **parallel** with the armature winding and combination across the load. As shown in the fig.

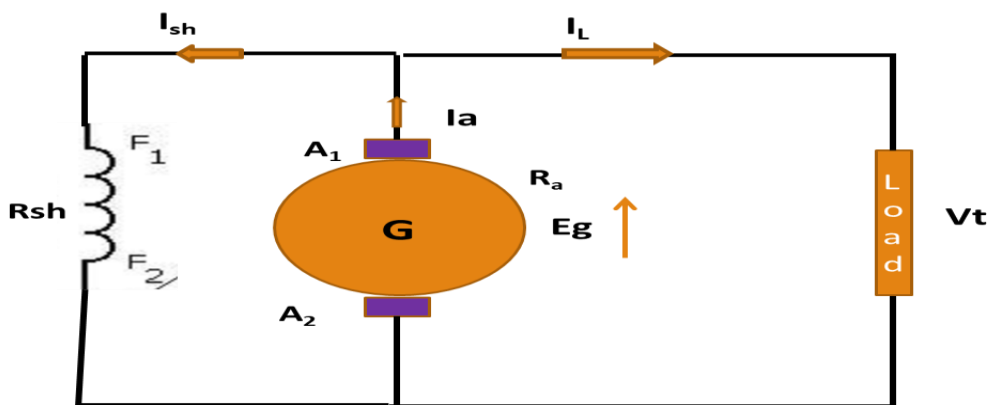

Ish- current through shunt field winding Rsh- Resistance of shunt field winding
 From the fig

Armature current $I_a = I_L + I_{sh}$ and $I_{sh} = \frac{V_t}{R_{sh}}$

Induced EMF $E_g = V_t + I_a R_a$

Terminal voltage $V_t = E_g - I_a R_a$

b) Series generator:

- In series generator, the field winding is connected in **series** with the armature winding and to the load. As shown in the fig.

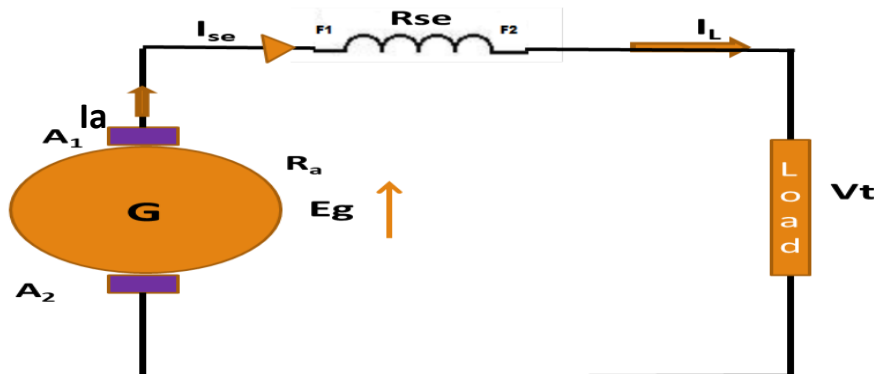

Ise- current through series field winding Rse- Resistance of series field winding

From the fig

Armature current

$$I_a = I_{se} = I_L$$

Induced EMF

$$E_g = V_t + I_a R_a + I_{se} R_{se}$$

$$E_g = V_t + I_a (R_a + R_{se})$$

$$[I_a = I_{se}]$$

Terminal voltage

$$V_t = E_g - I_a (R_a + R_{se})$$

Compound Generator:

- The compound generator has provided with magnetic field in combine with excitation of shunt and series field winding. The part of field winding is connected in parallel with armature called shunt field winding and part in series with armature winding called series field winding.
- There are two types of Compound generators such as
 - (i) Long shunt Compound Generator
 - (ii) Short Shunt Compound Generator

Short Shunt Compound Generator:

The shunt field winding is connected in parallel only with the armature. As shown in the fig.

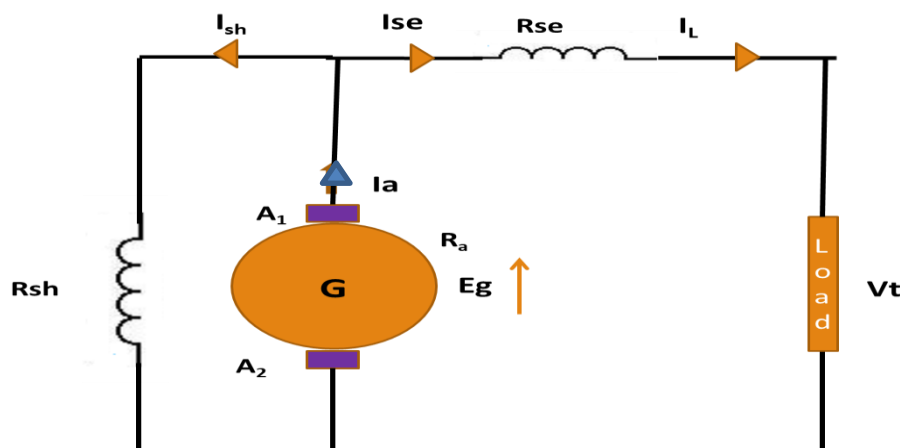

Long Shunt Compound generator: The shunt field winding is connected in parallel with the series combination of armature and series field winding.

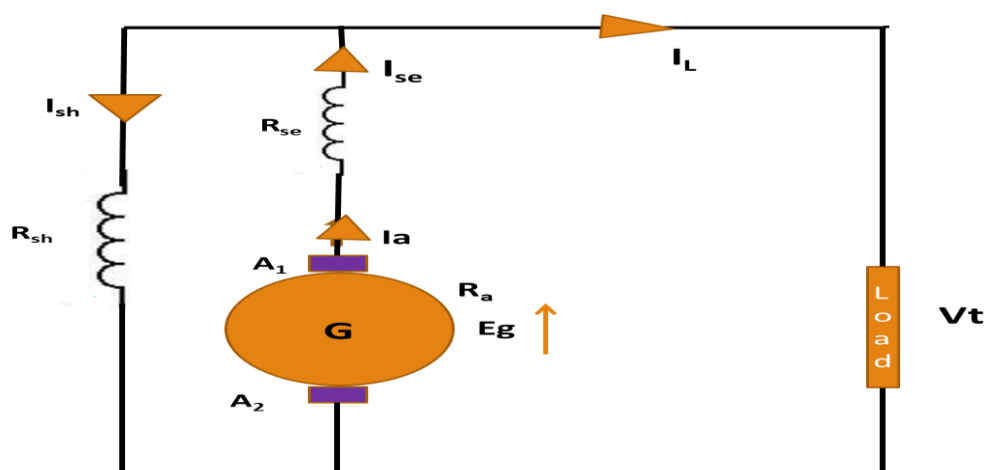

Problems:

1. The emf generated in the armature of a shunt generator is 625 volts, delivering its full load current of 400 A to the external circuit. The field current is 6 amps and the armature resistance is 0.06Ω . What is the terminal voltage?

Solution:

Given: $E_g=625$ V, $I_L=400$ A, $I_{sh}=6$ A, and $R_a = 0.06\Omega$ $V_t=?$

Wkt $I_a = I_L + I_{sh} = 400+6 = 406$ A

Terminal Voltage $V_t = E_g - I_a R_a$ (neglecting brush voltage drop)

$$= 625 - (406 \times 0.06)$$

$$V_t = 600.64\text{V}$$

2. A 30 kW, 300V, DC shunt generator has armature and field resistances of 0.05 ohm and 100ohm respectively. Calculate the total power developed by armature when delivers full output power.

Solution: $P_L = 30\text{kW}$, $V_t = 300$ V, $R_a = 0.05\Omega$, $R_{sh} = 100\Omega$ $P_a = ?$

Wkt the power developed in the armature $P_a = E_g \times I_a$

Therefore $P_L = V_t \times I_L$

$$I_L = \frac{P_L}{V_t} = \frac{30 \times 10^3}{300} = 100 \text{ A} , \quad I_{sh} = \frac{V_t}{R_{sh}} = \frac{300}{100} = 3 \text{ A}$$

$$I_a = I_L + I_{sh} = 100 + 3 = 103\text{A}$$

$$E_g = V_t + I_a R_a = 300 + 103 \times 0.05 = 305.15\text{V}$$

$$\text{Power developed by armature} = E_g I_a = 305.15 \times 103 = 31.4304\text{kW}$$

DC Motors

Operation of a DC motor:

- When a DC machine is loaded as a motor, the armature conductors carry current. These conductors lie in the magnetic field of the air gap. Thus, each conductor experiences a force. The conductors lie near the surface of the rotor at a common radius from its centre. Hence, a torque is produced around the circumference of the rotor, and the rotor starts rotating.

Working Principle of a DC motor

The principle of operation of the DC motor is "when a current carrying conductor is placed in a magnetic field, it experiences a mechanical force".

Consider a single conductor placed in a magnetic field as shown in the fig and the main flux produced by the poles.

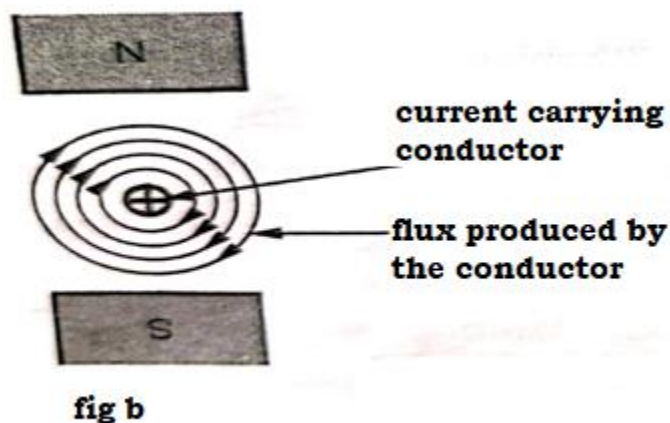
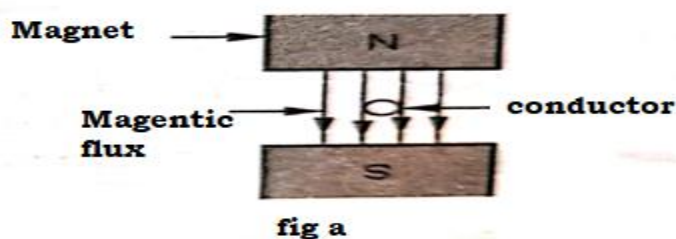

When conductor excited by a separate supply it carries a current in a particular direction. Consider the conductor carries the current away from an observer as shown in the fig.

Any current carrying conductor produces its own magnetic field around it hence, this conductor also produces its own flux around it. The direction of this flux can be determined by right hand thumb rule. It is observed that the direction of flux is in clockwise direction.

Now there are two fluxes present,

1. The flux produced by the poles called main flux.
2. The flux produced by the current carrying conductor.

These are shown in the fig

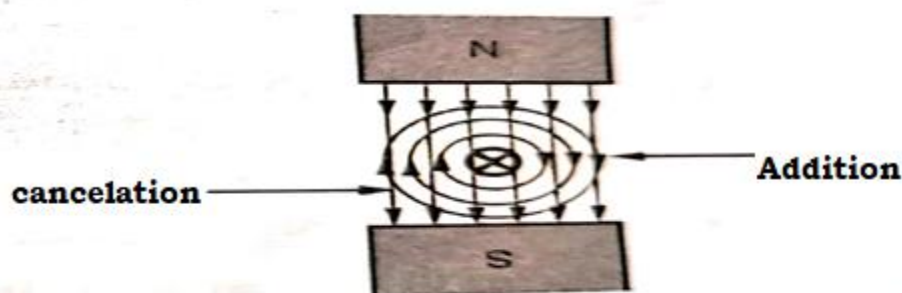

From this, it is clear that on one side (left side) of the conductor, both fluxes are in the same direction, there is gathering of the flux lines as two fluxes help each other.

As against this, on the left of the conductor, the two fluxes are in the opposite direction and hence try to cancel each other. Due to this, density of the flux line in this area gets weakened. So on the right, there exists high flux density area while on the left of the conductor there exists low flux density as shown in the fig.

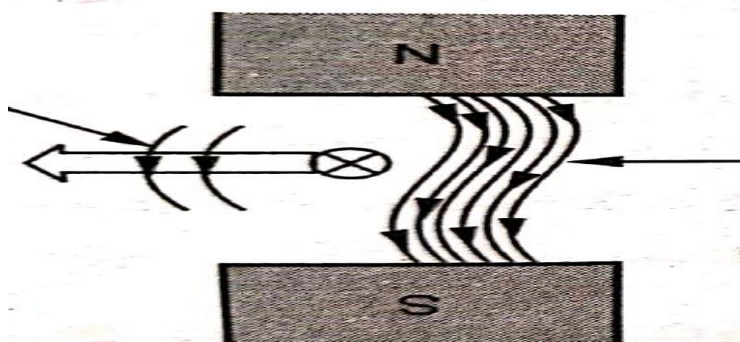

This flux distribution around the conductor acts like a stretched rubber band under tension. This exerts a mechanical force on the conductor which acts from high flux density area towards low flux density area, i.e. From left to right for the case considered as shown in the fig,

Back Emf and its Significance:

- When the Armature of D C motor starts rotating and armature conductor cuts the magnetic flux, hence an EMF is induced in the Conductor called **Back EMF**.
- The induced emf acts in opposite direction to the applied voltage 'V'(Lenz's law) , hence it is called as back EMF. It is given by

$$E_b = \frac{\phi P N Z}{60 A}$$

The Voltage equation of DC motor is $V = E_b + I_a R_a$

Therefore armature current

$$I_a = \frac{V - E_b}{R_a}$$

Significance:

- The basic Principle of the Back EMF is that $E_b \propto N$
- When the load suddenly put on the motor, motor tries to slow down. So speed of the motor reduces due to which the back EMF decreases. So the net Voltage ($V - E_b$) increases and motor draws **more armature current**.
- When the load on the motor decreases, the speed of the motor increases due to which the back EMF increases. So the net Voltage ($V - E_b$) decreases and motor draws **less armature current**
- Therefore due to the presence of back emf. The d.c. motor acts as a self-regulating machine. It regulates the flow of armature current i.e., it automatically changes the armature current to meet the load requirement

Torque equation of a DC Motor:

The turning and twisting force about an axis is called torque.

Consider a wheel of radius 'R' meters acted upon the circumferential force 'F' newtons as shown in fig

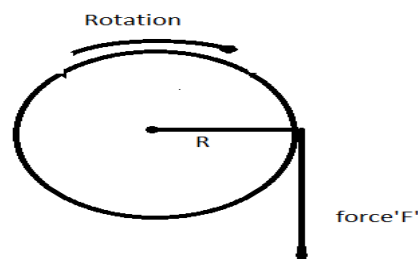

The wheel is rotating with speed of 'N' rpm then its angular speed is,

$$\omega = \frac{2\pi N}{60} \text{ rad/sec} \quad \text{-----1}$$

so work done in one revolution is

$$W = \text{force} \times \text{distance travelled in one revolution} = F \times 2\pi R \quad \text{joules}$$

$$\text{Power } P = \frac{\text{workdone}}{\text{time for 1 revolution}} = \frac{F \times 2\pi R}{\frac{60}{N}} = F \times R \times \frac{2\pi N}{60}$$

$$P = T \times \omega$$

Where T = Torque in Nm and ω = angular speed in rad/sec

Let ' T_a ' is torque developed in the armature of the motor. It is also called as **armature torque**.

The gross mechanical power developed in the armature is ' $E_b I_a$ '

Power in armature = armature torque * ω

$$E_b I_a = T_a * \frac{2\pi N}{60}$$

But,

$$E_b = \frac{\phi P N Z}{60 A}$$

Therefore

$$\frac{\phi P N Z}{60 A} * I_a = T_a * \frac{2\pi N}{60}$$

So, the torque equation is given as

$$T_a = \frac{1}{2\pi} X \frac{\phi I_a P Z}{A}$$

Types of DC Motors:

Motors are classified into 3 types: a) DC Shunt motor.

b) DC Series motor.

c) DC Compound motor.

a) DC Shunt motor:

- In shunt motor the field winding is connected in parallel with armature.
- The current through the shunt field winding is not the same as the armature current.

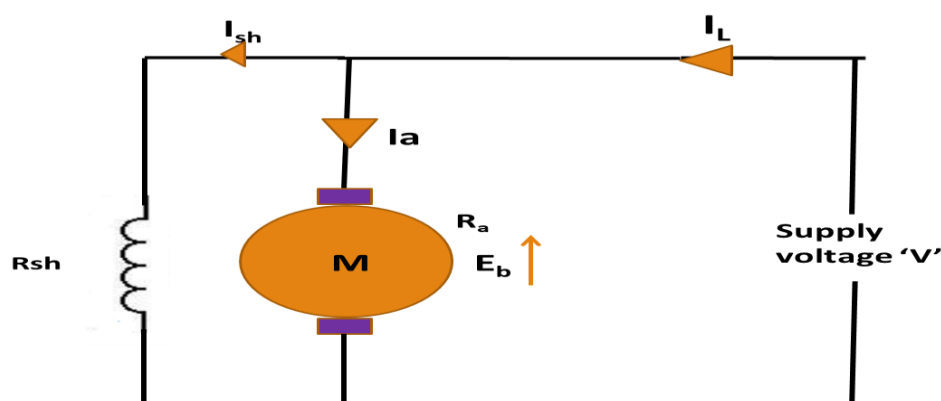

In above circuit

$$I_L = I_a + I_{sh} \quad \text{and} \quad I_{sh} = \frac{V}{R_{sh}}$$

$$V = E_b + I_a R_a$$

b) DC Series motor:

- In series wound motor the field winding is connected in series with the armature.
- Therefore, series field winding carries the armature current.

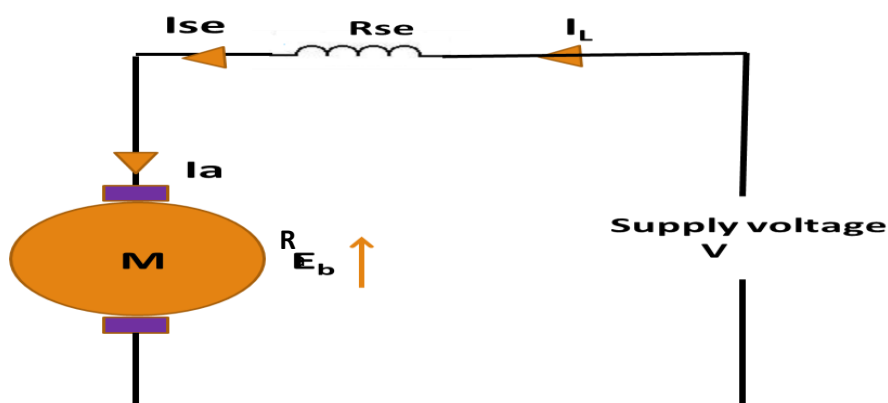

In above circuit

$$I_L = I_a = I_{se}$$

$$V = E_b + I_a R_a + I_{se} R_{se}$$

$$V = E_b + I_a (R_a + R_{se})$$

c) DC Compound motor:

- Compound wound motor has two field windings; one connected in parallel with the armature and the other in series with it.
- There are two types of compound motor connections :

1) Short-shunt connection Compound Motor

When the shunt field winding is connected in parallel with the armature winding it is called short-shunt connection.

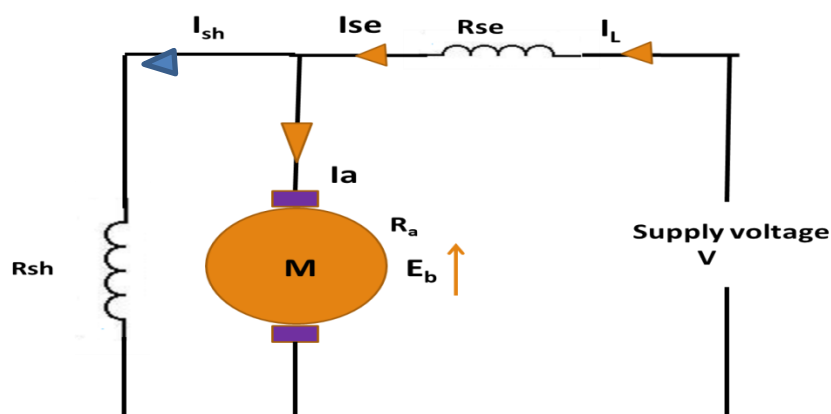

Long shunt connection Compound Motor when the shunt winding is so connected that in parallel with the series combination of armature and series field it is called long-shunt

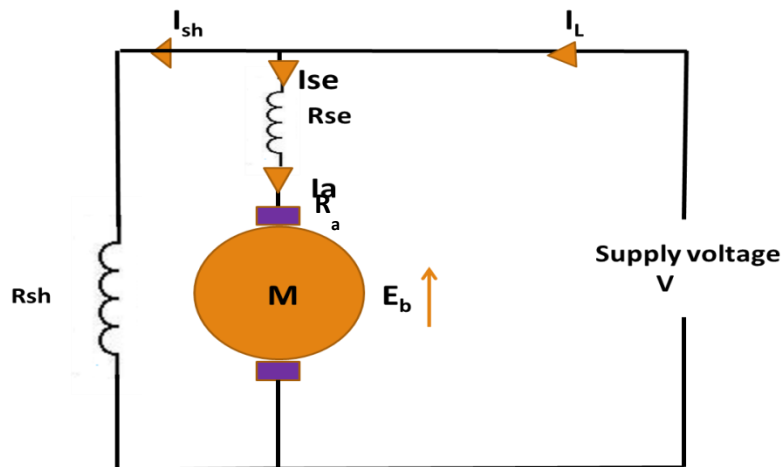

List of the formulas

$$1) E_b = \frac{\phi P N Z}{60 A}$$

$$2) \text{ Armature torque } T_a = \frac{1}{2\pi} \times \frac{\phi I_a P Z}{A}$$

$$\text{Shaft torque } T_{sh} = P / \omega$$

3) The mechanical power developed by the armature is $P_m = E_b I_a$

4) DC Shunt motor

$$I_L = I_a + I_{sh} \quad \text{and} \quad I_{sh} = \frac{V}{R_{sh}}$$

$$V = E_b + I_a R_a$$

5) DC series Motor $I_L = I_a = I_{se}$

$$V = E_b + I_a (R_a + R_{se})$$

PROBLEMS

1. A 4 pole DC motor takes 50A armature current. The armature has lap connected winding with 480 conductors. The flux per pole is 20mwb. Calculate the gross torque developed in the armature.

Solution: Given $P=4$ lap onnected $A = P = 4$

$$I_a = 40A \quad Z = 480 \quad \phi = 20 \times 10^{-3} \text{ wb} \quad T_a = ?$$

Wkt Armature torque $T_a = \frac{1}{2\pi} X \frac{\phi I_a P Z}{A}$

$$T_a = \frac{1}{2\pi} X \frac{20 \times 10^{-3} \times 40 \times 4 \times 480}{4}$$

$$T_a = 76.39 \text{ N-m}$$

2. A 200V, 4 pole, lap wound, d.c shunt motor has 800 conductors on its armature. The resistance of armature winding is 0.5 ohm & that of shunt field winding is 200 ohm. The motor takes a current of 21A, the flux/pole is 30mWb. Find the speed & gross torque developed in the motor

Solution: Given $V = 200 \text{ V}$ $P=4$ lap connected $A = P = 4$
 DC shunt motor $Z = 800$ $R_a = 0.5\Omega$ and $R_{sh} = 200\Omega$
 $I_L = 21A$ $\phi = 30 \times 10^{-3} \text{ wb}$
 $N = ?$ $T_a = ?$

Wkt $E_b = \frac{\phi P N Z}{60 A}$ $N = \frac{E_b \times 60 \times A}{\phi P Z}$

For DC Shunt motor

$$V = E_b + I_a R_a \quad \text{I,e } E_b = V - I_a R_a$$

$$I_L = I_a + I_{sh}$$

$$I_{sh} = \frac{V}{R_{sh}} = \frac{200}{200} = 1 \text{ A}$$

$$I_a = I_L - I_{sh} = 21 - 1 = 20A$$

$$\text{Therefore } E_b = V - I_a R_a = 200 - 20 \times 0.5$$

$$E_b = 190V$$

$$N = \frac{E_b \times 60 \times A}{\phi P Z} = \frac{190 \times 60 \times 4}{30 \times 10^{-3} \times 4 \times 800}$$

$$N = 475 \text{ rpm}$$

Armature torque $T_a = \frac{1}{2\pi} X \frac{\phi I_a P Z}{A}$

$$T_a = \frac{1}{2\pi} X \frac{30 \times 10^{-3} \times 20 \times 4 \times 800}{4}$$

$$T_a = 76.38 \text{ N-m}$$

3. A 4 pole, 220V , lap connected ,DC shunt motor has 36 slots, each slot has 16 conductors. It draws a current of 40A from the supply. The field and armature resistances are 110Ω and 0.1Ω respectively. The motor develop an output power of 6KW .the flux per pole is 40mwb calculate
- i) The speed
 - ii) Torque developed in the armature
 - iii) Shaft torque

Solution: Given $V = 220 \text{ V}$ $P=4$ lap connected $A = P = 4$

DC shunt motor $Z = 36 \times 16 = 576$

$I_L = 40 \text{ A}$ $R_a = 0.1 \Omega$ and $R_{sh} = 110 \Omega$

$P = 6 \times 10^3 \text{ W}$ $\phi = 40 \times 10^{-3} \text{ wb}$

$N = ?$ $T_a = ?$ $T_{sh} = ?$

$$\text{Wkt } E_b = \frac{\phi P N Z}{60 A} \qquad N = \frac{E_b \times 60 \times A}{\phi P Z}$$

For DC Shunt motor

$$V = E_b + I_a R_a \qquad \text{I,e } E_b = V - I_a R_a$$

$$I_L = I_a + I_{sh}$$

$$I_{sh} = \frac{V}{R_{sh}} = \frac{220}{110} = 2 \text{ A}$$

$$I_a = I_L - I_{sh} = 40 - 2 = 38 \text{ A}$$

Therefore $E_b = V - I_a R_a = 220 - 38 \times 0.1$

$$E_b = 216.2 \text{ V}$$

$$N = \frac{E_b \times 60 \times A}{\phi P Z} = \frac{216.2 \times 60 \times 4}{40 \times 10^{-3} \times 4 \times 576}$$

$$N = 563.02 \text{ rpm}$$

Armature torque $T_a = \frac{1}{2\pi} X \frac{\phi I_a P Z}{A}$

$$T_a = \frac{1}{2\pi} X \frac{40 \times 10^{-3} \times 38 \times 4 \times 576}{4}$$

$$T_a = 139.207 \text{ N-m}$$

Shaft torque $T_{sh} = \frac{P}{\omega}$

$$= \frac{6 \times 10^3}{2\pi N / 60}$$

$$= \frac{6 \times 10^3 \times 60}{2\pi \times 563.02} = 101.73 \text{ N-m}$$

4. 220 V series motor is taking a current of 40A, resistance of armature 0.5 ohms, resistance of series field is 0.25 ohms. Calculate

- i) Back Emf
- ii) Power wasted in armature, and power wasted in series field.

Solution: Given $V = 220$

DC Series motor $I_L = 40A$ $R_a = 0.5\Omega$ and $R_{se} = 0.25\Omega$

$E_b = ?$

$P_a = ?$

$P_{se} = ?$

Wkt DC series Motor $I_L = I_a = I_{se} = 40A$

$$V = E_b + I_a(R_a + R_{se})$$

Therefore

$$E_b = V - I_a(R_a + R_{se})$$

$$E_b = 220 - 40(0.5 + 0.25)$$

$$E_b = 190 \text{ V}$$

Power wasted in armature $P_a = I_a^2 R_a = 40^2 \times 0.5 = 800 \text{ W}$

Power wasted in series field $P_{se} = I_{se}^2 R_{se} = 40^2 \times 0.25 = 400 \text{ W}$

Characteristics of DC Motors:

The three important characteristic curves are

1. Torque V_s Armature current characteristic (T_a/I_a)
2. Speed V_s Armature current characteristic (N/I_a)
3. Speed V_s Torque characteristic (N/T_a)

DC Shunt Motor Characteristics:

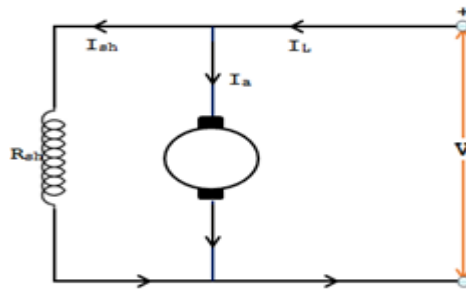

In DC shunt motor the field winding is connected in parallel with the source voltage, so the field current I_{sh} and the **flux** are constant in a shunt motor .

Torque V_s Armature current characteristic (T_a/I_a):

We know that in a DC Motor **$T_a \propto \Phi I_a$** by torque equation

The flux Φ is constant in shunt motor, therefore **$T_a \propto I_a$**

The torque increases linearly with the armature current

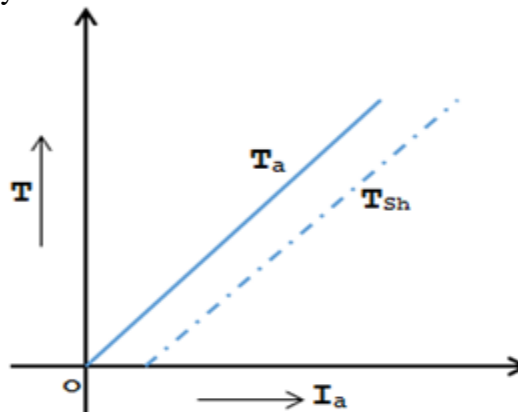

Speed V_s Armature current characteristic (N/I_a):

- $N \propto E_b$ and $E_b = V - I_a R_a$. As the flux is constant.
- When load increases, the armature current increases hence the drop $I_a R_a$ increases therefore $V - I_a R_a$ decreases hence speed decreases.

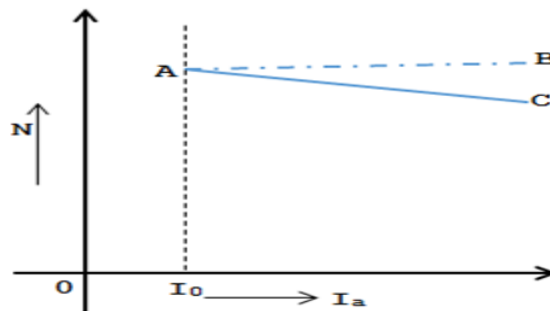

Speed V_s Torque characteristic (N/T_a): The speed reduces when the load torque increases.

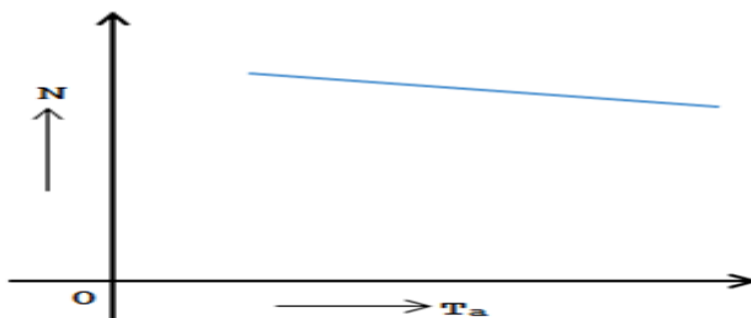
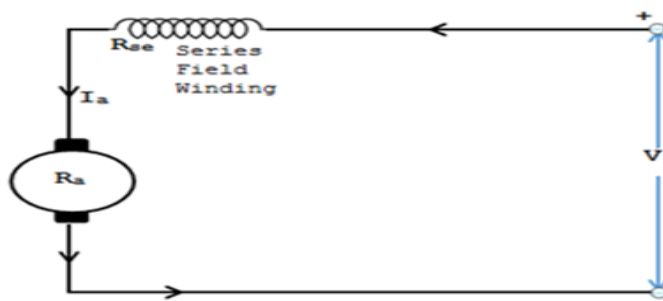
**DC Series Motor:**

In DC series motor the field winding is connected in series with the source voltage, so the field current I_{se} and the flux are not constant.

Torque V_s Armature current characteristic (T_a/I_a):

We know that

$$T_a \propto \Phi I_a$$

$$T_a \propto I_a^2$$

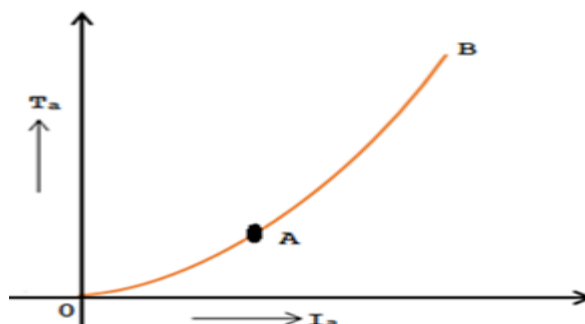

- The armature torque vs. armature current curve up to magnetic saturation is a parabola, which is shown in the characteristic curve OA.
- On the other hand once the magnetic saturation is reached, the T_a is directly proportional to the I_a .
- As a result the armature torque vs. armature current magnetic saturation characteristic is a straight line, which is shown in the curve AB.

Speed V_s Armature current characteristic (N/I_a):

In Series Motor

Speed --

$$N \propto (E_b/\Phi)$$

$$N \propto 1/I_a \Phi$$

$$N \propto 1/I_a^2$$

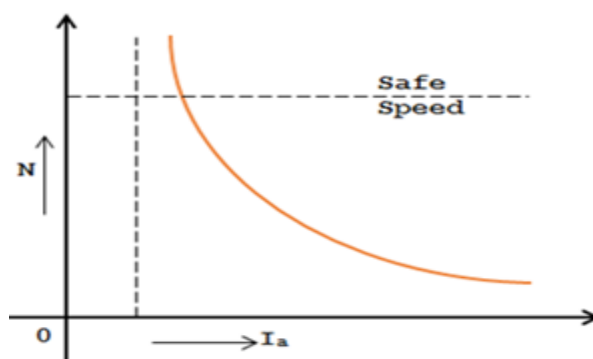

Speed V_s Torque characteristic (N/T_a): The speed reduces when the load torque increases.

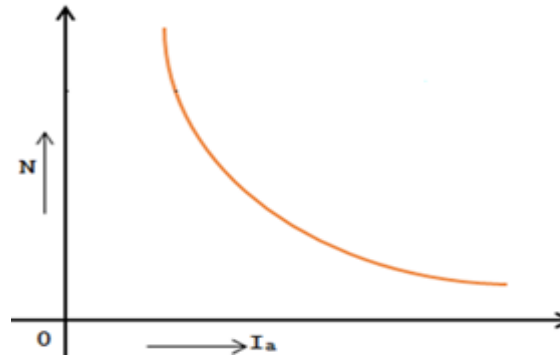

Speed control of dc motors : Field control method & Armature control method

1. DC Shunt motor

i) Field control method

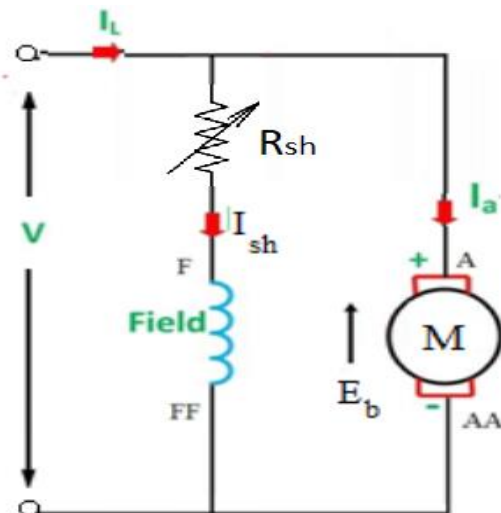

$$N = \frac{V - I_a R_a}{\Phi}$$

$$N \propto 1/\phi$$

$$\uparrow R_{sh} \implies I_{sh} \downarrow \implies \phi \downarrow \implies N \uparrow$$

ii) Armature control method

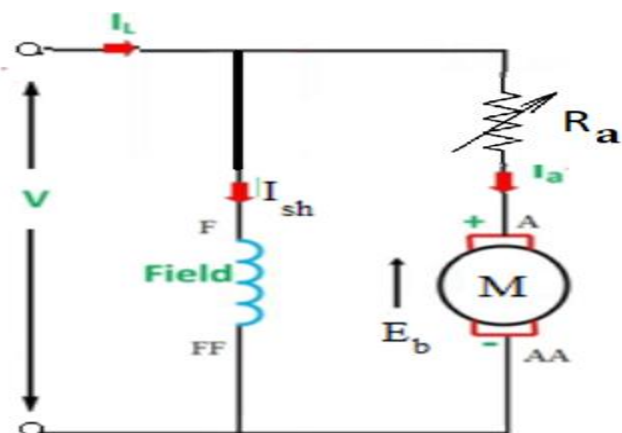

$$N = \frac{V - I_a R_a}{\Phi}$$

$$N \propto V - I_a R_a$$

$\uparrow R_a \implies I_a R_a \uparrow \implies V - I_a R_a \downarrow \implies N \downarrow$

2. DC Series motor

a) Field control method

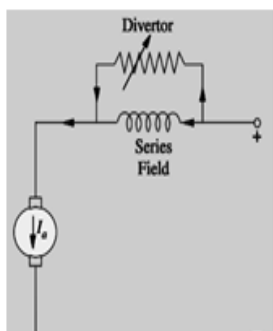

$$N \propto \frac{E_b}{\Phi} \propto \frac{V - I_a(R_a + R_{se})}{\Phi}$$

Diverter $\downarrow \implies I_D \uparrow \implies I_{series\ field} \downarrow \implies \Phi \downarrow \implies N \uparrow$

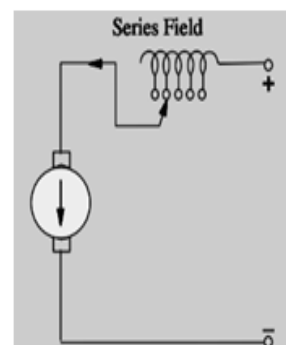

Full winding included gives min speed

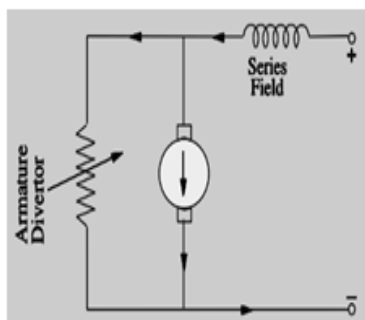

$T_a \propto \Phi I_a$
 Diverter $\downarrow \implies I_a \downarrow \implies \Phi \uparrow \implies N \downarrow$
 (To maintain const torque)

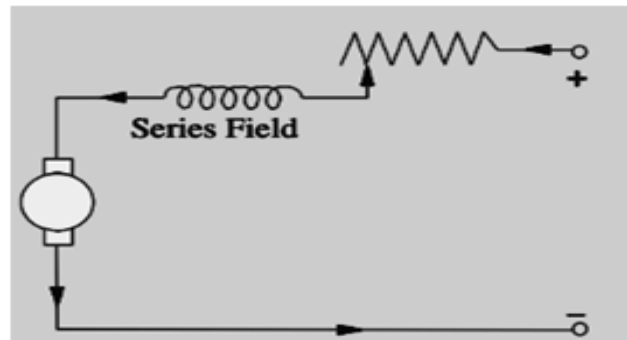
b) Armature control method

Series R \uparrow \implies v_a reduces \implies N reduces